

GENERAL DESCRIPTION

The MPM300 (Figure 1) is a high precision motion co-processing engine capable of nanometer level position measurement and supports high precision motion feedback control within a compact footprint.

The standard MPM300/OEM interfaces with a variety of precision linear, rotary, and recently introduced absolute encoders, made by a variety of encoder manufacturers including Nikon. NanoWave's close collaboration with Nikon resulted in the MPM300 processing unit to provide complete support for Nikon's DigiMicro encoder products. Some of MPM300's digital signal processing efforts was borrowed from NanoWave's patented Scanning Probe Position Encoder (SPPE) technology called NanoRES™ which offers many advantages over other encoding methods.

NanoWave has also taken advantage of the emerging high density FPGA's (Field Programmable Gate Arrays) to implement proprietary DSP (Digital Signal Processing) algorithms. Unlike conventional DSP ICs, FPGAs allow many parallel signal processing paths which greatly speed up real-time signal processing. Due to this reason, the MPM300 can process position data at tens of MHz sampling rates with uncanny accuracy which makes it ideal for machine control.

The MPM300 board also provides an integrated display driver for Optrex F-51852 LCD with a choice of colors* by customers.

* MPM300/OEM will come with a standard LCD connector and driver software.



Figure 1. USB Powered MPM300/OEM with LCD Display

STANDARD FEATURES

- 1 nanometer resolution FPGA core with Nikon Digimicro encoder.
- Automatic DC offset, amplitude and phase distortion compensation for A Quadrature B analog encoder input signals
- Direct connection to Nikon encoders
- 40MHz 1.2M gate FPGA technology
- Simultaneous two channel ADC (10MSPS @ 12bit is standard. Upgradeable to 80MSPS @ 14bit)
- USB 2.0 High Speed PC support
- Compatible with CP300 Windows 2K/XP/Vista based software
- .NET DLL for custom software development
- PID motion control core with 18-bit delta-sigma DAC ready output*
- A quad B digital position outputs
- USB powered
- Nikon "A" format interface compatible for absolute encoder
- 128x64 Graphics Display enabling 12 digits display
- Keypad interface
- 5 high-speed differential pairs for general purpose digital IO
- Automatic power management
- ROHS compliant

* Requires low pass passive components. Consult NanoWave for ultra fast DACs if required.

40 MHz FPGA Processing

The MPM300 features state of the art digital signal processing implemented in a 500K gate FPGA (Field Programmable Gate Array).

This technology provides extreme flexibility and quick customization. NanoWave has surrounded the FPGA core with mainstream peripherals such as USB 2.0 (up to 480Mb/sec transfer speed) and high speed ADC technology.

Nikon DigiMicro Encoder Support

The DigiMicro product line from Nikon is a family of diffraction-type optical encoder as shown in Figure 2.



Figure 2. Nikon MPM300 shown with Nikon MF-1001-MPM Encoder and MS-21 stand

These plunger-type head feature extremely smooth mechanical action, critical for nanoscale measurement. They are popular as digital height gauges but have many other uses and applications in motion control systems as well.

The encoders feature obtainable resolution down to 1 nanometer while maintaining sub-micron accuracy.

The encoder mechanism is enclosed in a sealed compact extruded-aluminum housing, which resists contamination and dirt. They are built with Nikon's traditional superior quality and reliability to help combat harsh industrial environments. The encoders install quickly, are easy to set-up or reuse, and have a wide variety of industrial and research applications.

Three models of the DigiMicro encoders (MH12-MPM, MF501-MPM and MF1001-MPM) are available through NanoWave with measurement ranges from 12mm up to 100mm. All models work with a MPM300/OEM also sold and supported by NanoWave.

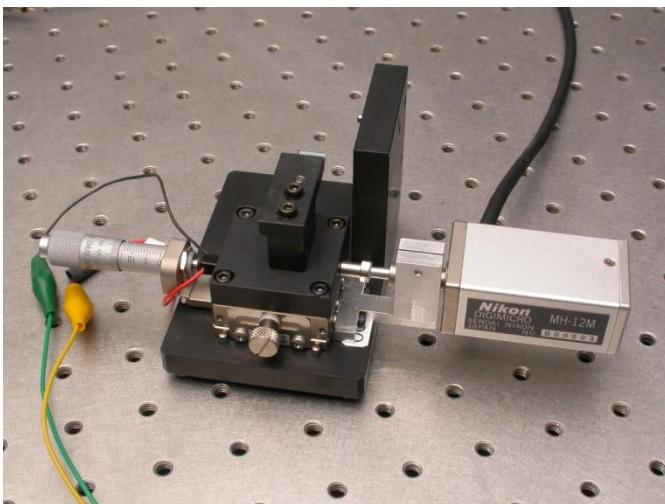

Figure 3 – Low-cost nano-stage build using Nikon DigiMicro MH12-MPM head, micrometer stage and piezo actuator.

Since all Nikon DigiMicro encoders are “on-axis” measurement instruments, they can be easily mounted on the relevant

measurement plane. As a result, Abbe errors are greatly reduced or even eliminated (vs. side-mounted encoders placed on underlying translational stages).

Unlike separate-type encoders, there is no need to mount and align read-heads with diffraction grating scales. This avoids many mechanical complications saving expensive engineering time while also eliminating a host of measurement errors, drift, and reliability problems, typical with this type of installations.

Nikon Absolute Encoder Support

Figure 4 shows Nikon's new linear absolute encoder (SAL-S40N), which is directly compatible with MPM300/OEM. The SAL-S40N is one of the first encoder in its class and size that is offered as a separate-type encoder (i.e. head and scale).

Nikon also manufactures rotary type absolute encoders, which are highly popular in East Asian countries serving industrial robotics for the automotive industries. The encoder interface uses and specifies its own proprietary A-format interface (#1 market share in Japan). The linear encoder head boasts a slightly better than 60nm resolution and has a 32mm measurement range.

Features:

- Nikon M-series one track absolute encoder technology
- No battery backup is needed to maintain position data.
- Simple to install reflection type micro head (8.2 × 12.7 × 25.0mm)
- Nikon A-format compatible (industry standard for absolute encoder)



Figure 4. Nikon M-series absolute encoder head - SAL-S40N

Other Encoder and Configuration Support

MPM300/OEM comes with two channel, high speed and high precision ADC, allowing flexible interface with many analog signal output encoders in the market.

It is possible even to achieve 32768x interpolation* at a rate faster than 10 MHz sampling rate. The integrated digital filter also allows high precision measurement without any speed penalty. Please consult NanoWave for further extension or custom design possibility based on the MPM300/OEM.

* 14bit ADC employment is assumed.

PC Support

While MPM300/OEM can work as a stand-alone measurement instrument, it is also compatible with **CP300**, a comprehensive graphical user interface based application which runs on Window 2K/XP/Vista based PC.

The PC communicates with MPM300 through a high-speed USB 2.0 interface (up to 60 KHz continuous position data sampling rate in our test using MS Windows XP). The software can be used to monitor static or dynamic position information as well as record and save trend data over time. Figure 5a shows the interface, which has the look and feel of a storage oscilloscope. The software also offers features like scale, amplitude, and sample rate adjustments, PID control, LCD contrast control, and digital position readout.

Features:

- Plug and Play
- Multi-lingual compatible (e.g. English, Japanese, Chinese)
- Fast and nano-precision servo loop using internal PID core and integrated differential delta-sigma DAC.

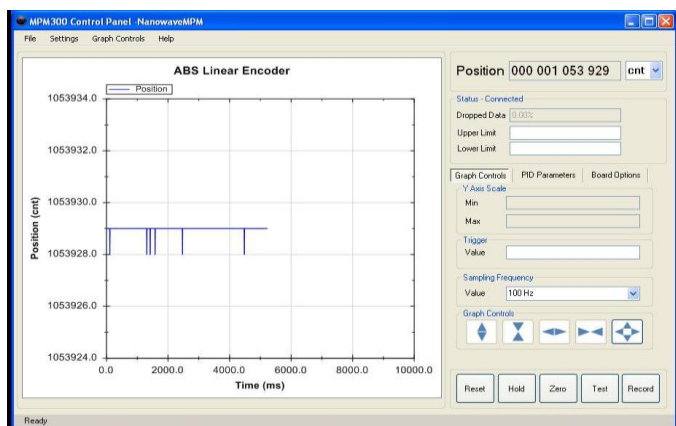

Figure 5a– CP300 Graphical Users Interface

Figure 5b shows the 2 nm-step response of the home-made nano-stage (shown in Figure 3) using MPM300/OEM and MH12-MPM encoder head. The piezo actuator is driven by a high voltage amplifier, whose input is connected to the 18-bit delta-sigma DAC on MPM300/OEM board.

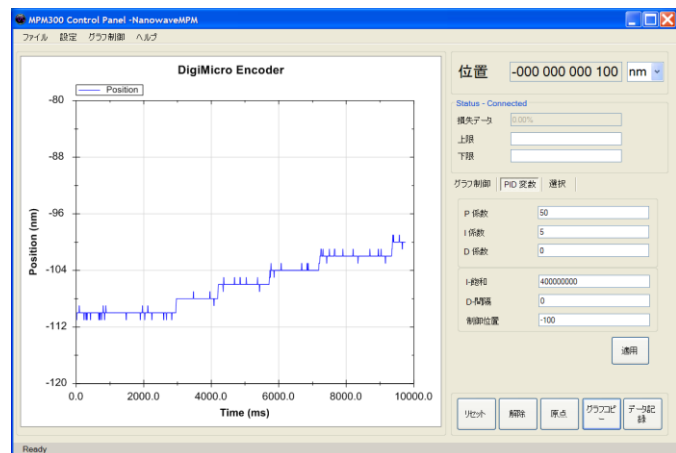

Figure 5b– CP300 Graphical Users Interface with integrated PID for 2nm step positioning test

Product Applications

- Optical fiber alignment
- Calibration Instruments
- Medical Equipment
- Robotics
- Industrial Automation
- Precision Machining
- Semiconductor Equipment



For motion control systems, the MPM300 combined with Nikon’s DigiMicro encoders provide a neat and compact solution as demonstrated in Figure 5b. The MPM300 also outputs standard A-Quad-B digital signals which can be supported by many commercially available counters and motion control boards.

On the other hand, Nikon SAL-S40N absolute linear encoder provides a perfect solution for systems which require:

- Encoder integration within a compact space
- Uninterrupted motion controller system after power outages due to safety concern etc.

MPM300/OEM is also directly compatible with any Nikon A-format absolute encoders.

APPENDIX: MPM300/OEM TECHNICAL SPECIFICATION

Earth ground is provided through the gold ring on the upper right-hand corner, which is connected to the shield of the top three connectors but not connected to the analog and digital ground on MPM300/OEM. See Figure 6.

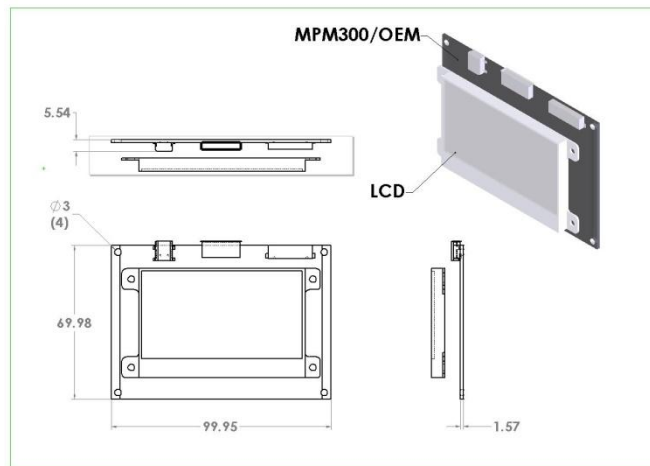

Figure 6. Mechanical drawing for MPM300/OEM

Input Connections

The MPM300 provides an 18-pin connector (JAE: DA1R018H91E) used to interface to the encoder head. An on-board 20-pin connector (JST SH series, BM20B-SRDS-A-G-TF) is provided for further OEM design flexibility. The 18-pin JAE connector is metal shielded which helps battle both static discharges and provides RF shielding. See Table 1.

Pin	Function	Specifications	I/O
1	+ A signal	12bit ADC @ 10MSPS	I

2	GNDA	Differential input pair possible 2 Vpp Max. @ 2 VDC bias.	I
3	Analog ground		
4	+ B signal	12bit ADC @ 10MSPS	I
5	GNDA	Differential input pair possible 2 Vpp Max. @ 2 VDC bias.	I
6	5V Analog power	Head Power. +5V @ 200ma Max.	
7	NA		
8	NA		
9	5V Analog power	+5V @ 50ma Max.	
10	Analog ground		
11	+ Z differential input/ A format data	Digital differential input pair 5V tolerant	I/O
12	- Z differential input/ A format data	Used for zero index pulse A-format data transmission	I/O
13	Digital ground		
14	+ A differential input	Digital differential input pair 5V tolerant	I
15	- A differential input	A quad B receiver input / A	I
16	Digital ground		
17	+ B differential input	Digital differential input pair 5V tolerant	I
18	- B differential input	A quad B receiver input / B	I

Table 1 - Input Pin Assignments

Input/Output Connections

A 24-pin connector is used to output A-Quad-B digital signals, PWM, Delta-Sigma DAC signal. Global synchronization clock and external sampling clock can also be input through the connector. On-board 40-pin connector (JST SH series, BM30B-SRDS-A-G-TF) may be provided for further OEM design flexibility. See Table 2.

Pin	Function	Specifications	I/O
1	General purpose I/O	single end	I/O
2	GNDA		
3	General purpose I/O	single end	I/O
4	GNDA		
5	GNDD		
6	Global clock		I/O
7	GNDD		
8	VCC3V3		
9	+ A (A quad B)	Digital differential input/output pair. 3.3 Vpp Max.	O
10	- A (A quad B)	A quad B output / A	O
11	+ B (A quad B)	Digital differential input/output pair. 3.3 Vpp Max.	O
12	- B (A quad B)	A quad B output / B	O

13	+ DAC1_P	Digital differential input/output pair. 3.3 Vpp Max.	O
14	- DAC1_N	Delta-Sigma DAC	O
15	+ Z (Index)	Digital differential input/output pair. 3.3 Vpp Max.	O
16	- Z (Index)		O
17	+General purpose I/O	Digital differential input/output pair. 3.3 Vpp Max.	O
18	- General purpose I/O		O
19	VCCA5		
20	GNDA		
21	+ EX_SP_CLK	External sampling clock input (single end)	I
22	General purpose I/O	single end	I/O
23	General purpose I/O	single end	I/O
24	General purpose I/O	single end	I/O

Table 2 – Input/output Pin Assignments

The MPM300 also provides 13-pin interface used for keypad interfacing, which can also be used for general purpose I/O. See Table 3.

Pin	Signal Name	Function	Specifications	I/O
1	GNDD	Digital ground		
2	VCC3V3	3.3V Digital power	+3.3V @ 200ma Max.	
3	KEY_0	Softkey 0		I
4	KEY_1	Softkey 1		I
5	KEY_2	Softkey 2		I
6	KEY_3	Softkey 3		I
7	NU	GPIO 0		
8	NU	GPIO 1		
9	NU	GPIO 2		
10	NU	GPIO 3		
11	NU	GPIO 4		
12	NU	GPIO 5		
13	NU	GPIO 6		
14	NU	GPIO 7		
15	NU	GPIO 8		
16	NU	GPIO 9		

Table 3 – Key pad and general purpose I/O Pin Assignments

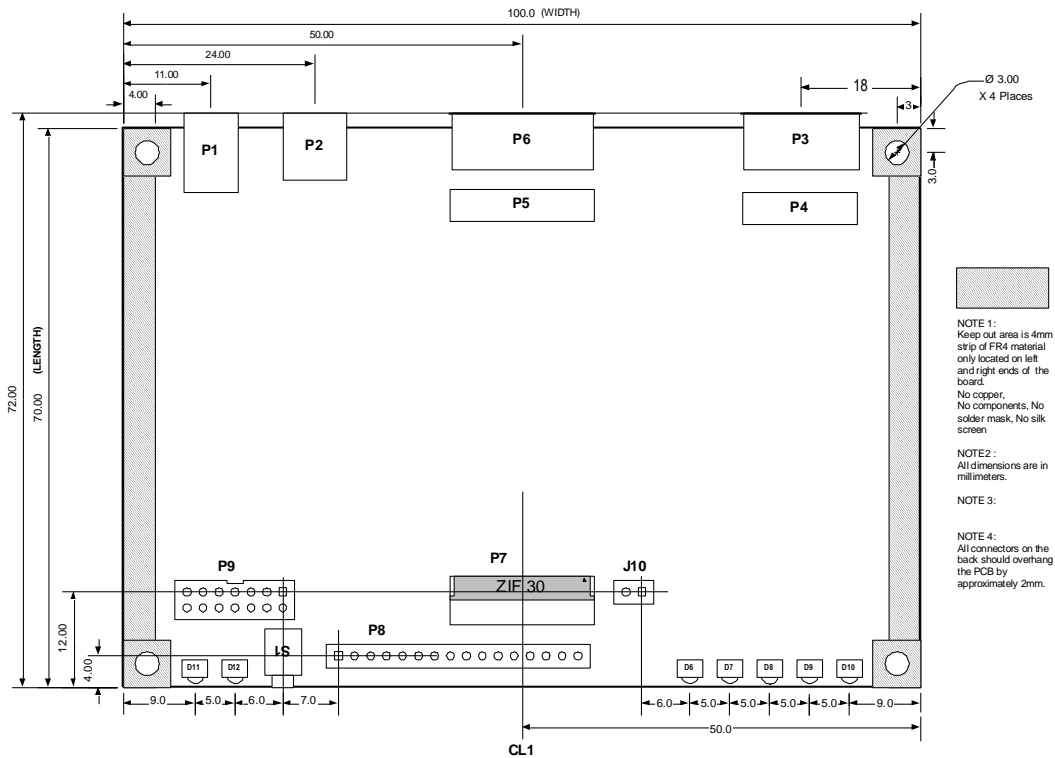

MPM300/OEM Printed Circuit Board (Component Side)

- P1 - not used -
- P2 - UX60-MB-5ST (Hirose USB Mini-B Receptacle Metal Shield SMT With Positioning Post)
- P3 - DA1R018H91E (JAE - CONN RECEPT 18POS 0.6MM R/A SMD)
- P4 - BM20B-SRDS-A-G-TF (JST - CONN HEADER SHD 20POS TOP W/BOSS)
- P5 - BM30B-SRDS-A-G-TF (JST - CONN HEADER SHD 30POS TOP W/BOSS)
- P6 - ST60-24P (Hirose - RTangle SMD Conn Recept 24 POS)
- P7 - FH12F-30S-0.5SH (Hirose - 0.5mm Pitch Bottom Contact ZIF Connector)
- P8 - PRPN161PAEN (Sullins - 1x16 2mm Header)
- P9 - 87331-1420 (Molex - Shrouded 2mm Header - 87832-1420)
- J10 - B2B-PH-K-S(LF) (SN) (JST SALES AMERICA INC - CONN HEADER PH TOP 2POS 2MM)



Figure 7 – MPM300/OEM Board Only



Figure 8 – MPM300 with cable, and wall USB power supply.
Enclosure design may vary.

Distributed & Supported by NanoWave

NanoWave is pleased to bring these advanced measuring Instruments to the North American market with technical support and advanced engineering services. We have over 30 years of combined experience in high-performance, high precision measurement and motion control systems.

NanoWave has also teamed with Nikon Corporation to leverage their advanced encoder technologies and widely respected manufacturing expertise to bring new market opportunities.

For more information on products, services, prices, and deliveries, please visit our website at www.nanowave.com or send any questions to info@nanowave.com

Authorized Nikon encoder products distributor in North America

The trademarks, service marks and logos (the "Trademarks") used and displayed in this document are registered trademarks of their respectable owner(s). The Nikon name and trademark is the sole property of Nikon Corp.



NanoWave, Inc.
PO Box 490
Sutton, MA 01590 USA

www.nanowave.com
info@nanowave.com

(888) 415-6555 Toll-free
(857) 413-4901 Office
(857) 413-4906 FAX